

Schilling Robotics RigMaster Manipulator

For nearly every TITAN 4 manipulator in the market, there is a RigMaster supporting the mission. Its titanium construction makes it a durable and reliable in heavy work class missions.

- Structural Strength and Long Service Life
- Large Operating Envelope
- Highest Lift-to-Weight Ratio in its Class
- Interchangeable Jaw Configurations
- Boom Function Extends Arm Length by 305mm
- Standard Depth Rating of 6,500msw

The RigMaster is a five-function, rate-controlled, heavy lift grabber arm that can be mounted on a wide range of subsea ROVs. It is engineered for the strength needed to withstand the industry's harsh and repetitive needs day after day. The grabber arm can be used to grasp and lift heavy objects or to anchor the ROV by clamping the gripper around a structural member at the work site.

It is constructed to be reliable in situations that require rugged operation. The arm's linear actuators have been life tested under full load for 250,000 cycles with minimal wear. The actuators use the latest cap seal technology to minimize leakage, ensuring long life and minimal maintenance. Its construction is of primarily titanium for structural strength, light weight, corrosion resistance, and extraordinary resistance to damage from collisions. RigMaster manipulators have a proven track record of reliability in the world's most demanding subsea environments.

Lift to Weight Ratio

The RigMaster has the highest lift-to-weight ratio of any manipulator in its class. Weighing only 48kg in seawater, its titanium linear actuators allow the manipulator to lift 270kg when the boom is retracted and 181kg at full arm extension. The wrist, which provides continuous 360-degree rotation, is driven by a high-torque, low-speed gerotor hydraulic motor that produces 205Nm of torque.



System configurations

On an ROV, this arm is typically paired with a dexterous manipulator arm such as a TITAN, CONAN, or ORION model. The standard arm is configured for left-hand installation, so that a dexterous arm can be mounted on the right. The RigMaster arm can be stowed vertically or horizontally to accommodate a range of ROV configurations. No electrical connections are required for the arm. Each joint or function is supplied by two hydraulic hoses that can be controlled with simple, customer-supplied valves and a switch box. An optional ergonomic rate hand controller is available for manipulator operation.

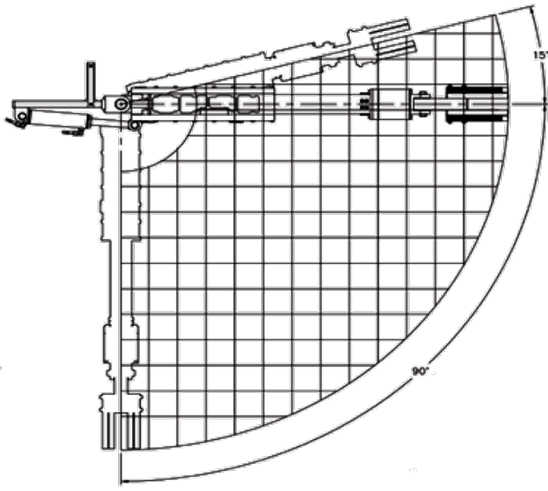

Range of motion, top view

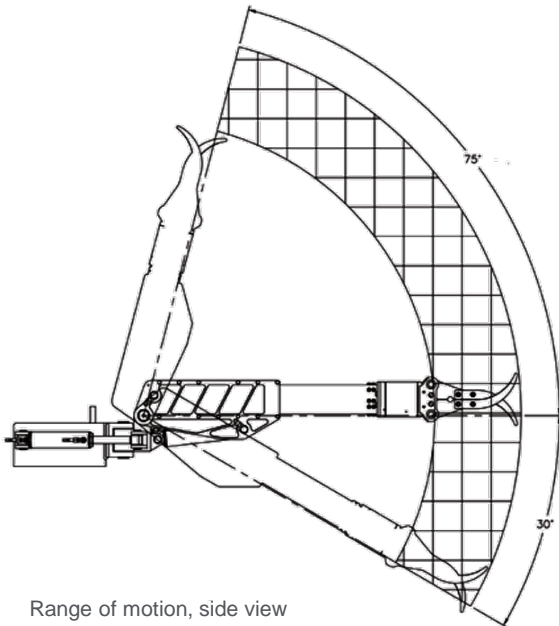

Range of motion, side view

7 P/R Specifications

Reach	1,372mm
Type	Rate controlled
Functions	5
Materials	Anodized aluminum, stainless steel, titanium

Arm specifications

- Standard depth: 6,500 msw
- Weight in air: 64kg
- Weight in water: 48kg
- Lift at full extension: 181kg
- Maximum lift, nominal: 270kg
- Standard Gripper Opening: 289mm
- Grip Force, nominal: 4,448N
- Wrist torque, nominal: 205Nm
- Wrist rotate, continuous: 6-35rpm

Actuator function

- Base yaw: Linear, 105°
- Shoulder pitch: Linear, 105°
- Boom, extend/retract: Linear, 305mm
- Wrist pitch: Linear, 120°
- Wrist rotate: Gerotor, 360°
- Gripper, standard: Linear, 284mm

Hydraulic Requirements

- Fluid: Mineral, Glycol, or Synthetic
- Viscosity: 10-200 cSt
- Available flow: 5.7 - 19 lpm
- Max. pressure: 3,000 psi
- Max fluid temperature: 54°
- Fluid cleanliness: ISO 4406 14/11
- Filtration: 10 microns

Corporate

TechnipFMC plc
11740 Katy Freeway
Houston, Texas 77079 (USA)
O: +1 281 591 4000

TechnipFMC

Schilling Robotics, LLC
201 Cousteau Place
Davis, California 95618 (USA)
P: +1 530 753 6718