

Schilling Robotics UHD-II ROV

The UHD-II vehicle delivers market leading performance for the most arduous deepwater construction tasks, and offers enhanced flexibility for survey and IRM applications.

- Delivers Industry Leading 200hp Ultra-Heavy, ROV Performance and Provides Automatic Power Efficiency Management
- Intelligent Power Management System
- Advanced Automatic Control Modes
- AutoTrack™ Utility Enables the Survey System to Control Vehicle Movement
- User Configurable Digital Telemetry System™(DTS™) Featuring a Gigabit Ethernet Backbone that Accommodates any Configuration of Sensors and Video Cameras
- High Ethernet Definition Video (HDEV) Capability as Standard
- Dedicated Propulsion and Tooling Hydraulic Circuits
- Unparalleled Stability for Survey Operations



It delivers the performance and efficient hydraulic power required in an ultra-heavy, work-class ROV. The rugged and powerful system is designed to accommodate the growing market for ultra-heavy tasks, such as suction pile installation, flying lead installation, and other applications that benefit from re-directing power to tooling operations.

The UHD-II has a substantial payload capability of 300kgf, when including the standard equipment and auxiliary hydraulics system option. This enables a wide variety of intervention tooling to be integrated to the ROV without having to add buoyancy.

Frame

The UHD-II frame provides 3,500kg through-frame lift capacity, incorporating a standard interface for the attachment of tooling skids underneath the vehicle and simple attachment of additional equipment to the fore and aft sides of the ROV. The UHD-II's spacious and modular design provides extensive onboard deck space, enabling simple integration of accessory equipment.

Control System

All Schilling Robotics ROVs utilize an innovative DTS system for control telemetry. Three DTS nodes are installed as standard. A maximum of 48 channels are available for vehicle equipment and customer interfaces, including five video and twelve data modules that can be configured for customer equipment requiring power and telemetry. The control system is expandable by additional nodes in 16 port configurations. Total Instrument power of 9kVA, 120VAC, and 26VDC is available.

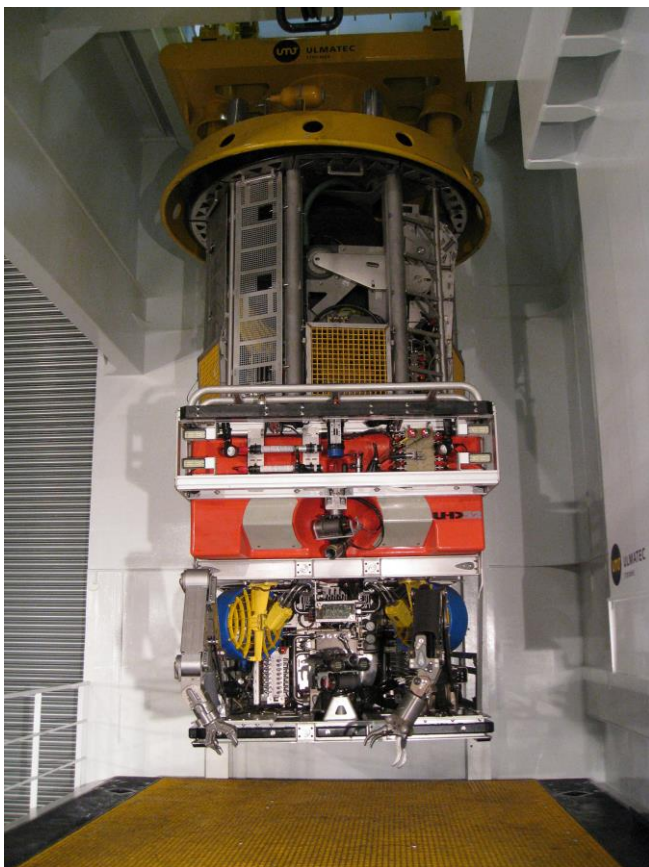
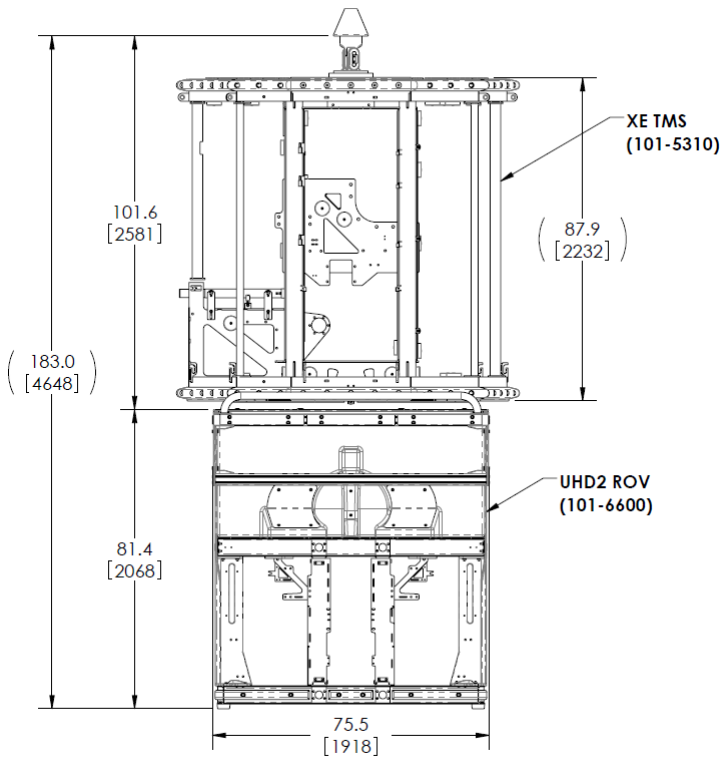

Specifications

Working Depth	3,000 mts & 4,000 mts
Docking Interface SWL:	8,770kg
Through-Frame Lift:	3,500kg
Weight in Air:	5,000kg
Dimensions:	3,0m X 1.9m X 2.1m
Payload:	300kg

Peak Thrust Performance

- Forward/ Aft/ Lateral: 1,200kgf
- Vertical - Up/ Down: 1,000kgf

Equipment Fit

- Manipulators: Any Schilling Model
- Cameras: SD and HD Options
- Depth Sensor: Valeport
- Heading Sensor: IXblue Nano
- DVL: Teledyne
- Lights: 8 x 120VAC and 2 x 24VDC
- Pan and Tilt: Schilling Electric
- Valves: (14) 8LPM , (2) 32LPM , (1) 160LPM

Hydraulic System

- HPU: 200-hp
- Auxiliary: 54-hp
- Operating Pressure: 207Bar
- Thrusters: (7) Sub Atlantic

Hydraulic Requirements:

- Fluid: Mineral, Glycol, or Synthetic
- Viscosity: 10-200 cSt
- Available Flow: 5.7 - 19 lpm
- Max. Pressure: 3,000 psi
- Max. Fluid Temperature: 54°C Fluid Cleanliness: ISO 4406 14/11

Corporate

TechnipFMC PLC
11740 Katy Freeway
Houston, Texas 77079 (USA)
P: +1 281 591 4000

Schilling Robotics LLC
201 Cousteau Place
Davis, California 95618 (USA)
P: +1 530 753 6718

TechnipFMC.com

© Copyright TechnipFMC 2021. v 1.0. All rights reserved.

Schilling Robotics UHD-II ROV | 2